



**LOIRE MAINE  
MANUTENTION**

Vente, location et entretien



**C 500 H  
C 500 H x4**



**FullGrip® System exclusivo AUSA:**  
Tracción integral por discos múltiples conectable  
electro-hidráulicamente desde el mando joystick.

**Exclusive AUSA FullGrip® System:**  
On demand 4WD connectable by means multiple discs  
with electro-hydraulic engagement from the joystick.

**FullGrip® System de AUSA:**  
4 RM sur demande au moyen de disques multiples  
avec connexion électro-hydraulique depuis le joystick.

**AUSA FullGrip® System:**  
Elektrohydraulisch, zuschaltbarer  
Allradantrieb – am Joystick zu betätigen.



[www.ausa.com](http://www.ausa.com)

**AUSA Center, S.L**  
Ctra. de Vic Km 2.8  
08243 Manresa  
**BARCELONA (ESPAÑA)**  
Tel.: +34 93 874 73 11  
E-mail: [ausa@ausa.com](mailto:ausa@ausa.com)  
[www.ausa.com](http://www.ausa.com)



**AUSA Madrid** Pol. Ind. Coslada - C. Marconi 15-17, 28823 Coslada - MADRID (ESPAÑA) - Tel.: +34 91 669 00 06 - E-mail: [ausa.madrid@ausa.com](mailto:ausa.madrid@ausa.com)  
**AUSA France** Z.I. Saint Charles - Rue de Zürich, 66000 PERPIGNAN (FRANCE) - Tel: +33 (0) 4 68 54 38 97 - E-mail: [ausa.france@ausa.com](mailto:ausa.france@ausa.com)  
**AUSA Deutschland** Tel.: +49 (0) 2384 9889905 - E-mail: [ausa.deutschland@ausa.com](mailto:ausa.deutschland@ausa.com)  
**AUSA UK** Tel.: +44 (0) 7970639988 - E-mail: [ausa.uk@ausa.com](mailto:ausa.uk@ausa.com)  
**AUSA Brasil** Avenida Belizario Ramos 2276 - Lages - SC, 88506-000 (BRASIL) - Tel.: +55 11 9 8786 6014 - E-mail: [ausa.brasil@ausa.com](mailto:ausa.brasil@ausa.com)  
**AUSA México** Calzada Vallejo 725 Del. Gustavo A. Madero - 07750 México D.F. (MÉXICO) - Tel.: +52(55) 21669276 - E-mail: [ausa.mexico@ausa.com](mailto:ausa.mexico@ausa.com)  
**AUSA U.S. CORP.** Tel.: +1 (917) 328 0770 - E-mail: [ausa.us@ausa.com](mailto:ausa.us@ausa.com)  
**AUSA Beijing Rep. Office** Room 403, Moma Building, N.199 - Chaoyang bei road, Chaoyang District - 100026 BEIJING (CHINA)  
Tel.: +86 10 8598 7386 - E-mail: [ausa.china@ausa.com](mailto:ausa.china@ausa.com)

**C 500 H/x4\_5000Kg**

DIMENSIONS (mm)		
	C 500 H	C 500 Hx4
A	2335	2335
B	270	280
C	300	300
D	1640	1700
E	2000	2000
F	3560	4380
G	3050	3205
I	130	130
J	60	60
K	728	728
L	4623	4623
M	705	645
N	1990	2050
O	1200	1200
P	5680	6820

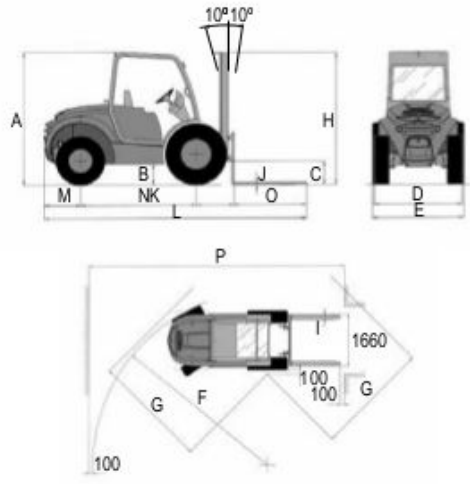

**AUSA**  
www.ausa.com

Type of mast	Maximum lifting height (mm)	Free H (mm)	Machine height with mast retracted (mm)		Machine height with mast extended (mm)		Load (Kg) at max. height according stability test standard (AYB)	
			C 500 H	C 500 Hx4	C 500 H	C 500 Hx4	(A)	(B)
Duplex (Std.)	3700	100	2750	4585	5000	5000	5000	5000
Duplex	4500	100	3150	5385	4800	4800	5000	5000
Triples (free lift)	4250	1393	2350	5262	5000	5000	5000	5000
Triples (free lift)	5450	1793	2750	6462	1500	1500	4250	4250
Triples (free lift)	6800	2243	3200	7812	600	600	3000	3000

**TECHNICAL SPECIFICATIONS**

	C 500 H	C 500 Hx4
Load capacity (Kg) @ Centre of gravity	5000 a 600mm	
Lifting height (Standard duplex mast) (mm)	3700	
Engine	Turbodiesel Deutz TD 3.6 L4	
EU Stage IIIB	Power acc/ SAE J 1995 (KWHP) 5575	
	N° of cylinders 4	
	Cooling system Agua	
	Post combustion treatment technology Diesel Oxidation Catalyst (DOC)	
Engine	Turbodiesel KUBOTA V 3600-T (IDI)	
EU Stage IIIA	Power acc/ SAE J 1995 (KWHP) 63 / 85,6	
	N° of cylinders 4	
	Cooling system Water	
Traction	4x2 with selflock limited slip differential in front axle	4x2 / 4x4 FullGrip®
Transmission	Hydrostatic with variable flow pump and automatic regulation Electric gear in joystick Inching pedal	
Unladen weight (Kg) (with full tanks)	7500	7600
Gradient negotiable (with full load)	30%	
Speed (Maximum) (Km/h)	20	
Engine starting system	Electric	
Tyres	Front 18-19.5 TL 16 PR (C500H / Hx4) Rear 8.15-15 (C500H) - 10.0 / 75-15.3 (C500Hx4)	
Steering	Hydraulic. Working pressure 150 bar	
External turning circle (mm)	3560	4380
Tank capacity (l)	Fuel 120 Hydraulic fluid 95	
Service brake	Oil-immersed, multidisc, hydraulically driven	
Parking brake	Oil-immersed, multidisc, hydraulically driven	
Hydraulic circuit	30 - 10.6 cc. double gear pump	
Operating pressures for accessories (bar)	230+5	
Fork carriage	FEM 4 - Width:1660 mm	
Stability test standard	(A)* For rough terrain use - Models H - EN 1726-1; Annex H (B)* For industrial use - Models HI - ISO 1074	

**STANDARD EQUIPMENT**

**OPTIONAL EQUIPMENT**

Open and tilting cabin
Ergonomic and comfort seat with height, weight and distance adjustable with seat belt
Rear-view mirrors
Joystick with integrated functions
Rotating beacon
Audible reverse warning
3th auxiliary hydraulic service
Side-shift
Semi-closed cabin
Closed cabin with heater
Air conditioning
Electronic anti-theft protection system
Radio/Stereo CD
Homologated lighting system
Catalytic converter
Spark arrester
Limited slip differential in front axle (Only mod. C 500 H Version HI)
4th auxiliary hydraulic service
5th auxiliary hydraulic service
600, 800 and 1000 l hydraulic buckets
Load backrest
Enhanced heater for Nordic countries
Many other attachments fitted with manufacturer warranty

AUSA reserves the right to make any changes in the specifications without prior notice.